



Product Catalogue
View the catalogue with the app



**HANSEN
HANSEN
■■■■ELECTRIC**

COMPLETE ELECTRIC SOLUTION FOR MINING

- *One of the major international producer in the field of coal mining industry*
- *Strong technical department, developing own Know-How, "Tailor Made" products*
- *60 years of history, experiences and innovations*
- *25 countries with our products and 16 countries with operated equipment in the mines*
- *6 daughter companies owned by Hansen Electric and other representative offices around the world*

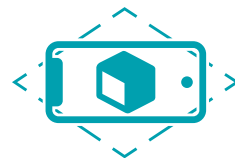
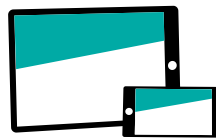

3D CATALOGUE
AR

3D CATALOGUE

Download application
HANSEN ELECTRIC



ABOUT COMPANY

Hansen Electric, spol. s r.o. is a highly developed company which is using modern technologies and Know-How in order to provide development, design, production, installation and maintenance for electric equipment used in potentially explosive atmospheres.

Our experience and original technology have their roots in the German company. For several decades we have been developing our unique Know-How, thanks to which Hansen Electric is a respected brand of the highest European quality.

The company has got a strong department of design and development, enabling us to customize the equipment according to customer requirements and develop some new products.

Broad product range enables the supply of complete electrical equipment for mining technologies.

HANSEN ELECTRIC PRODUCTION

- **Transformer sets with or without load centers (power up to 4.5 MVA, input voltage up to 11kV, secondary voltage up to 4.1kV)**
- **Load centers / Compact stations (up to 1800kW output, up to 3300V)**
- **Sets for a Soft Start (outputs up to 4 x 315kW, up to 1200V)**
- **Frequency invertors (outputs up to 2 x 800kW, up to 3300V)**
- **Circuit breakers-distribution fields (up to 10kV)**
- **Intrinsically safe control systems for the programming of mining excavating technologies with speech communication, monitoring and the visualisation**
- **Light fittings for the coalface and corridors, as well as signalling lamps**
- **Electric motors (55, 75, 100, 160 and 250kW, from 500V to 1200V)**
- **Vacuum contactors up to 630A, up to 1200V or 3300V**

Besides the production activity in underground mining, Hansen Electric also repairs electric motors of all kinds and types of voltage up to 6kV, repairs and services mining machinery drives, and repairs and manufactures new generators of power outputs up to 10MW.

Every Hansen Electric product is certified in accordance with European ATEX standards, all standards applicable in the countries they are to be delivered to, and undergoes strict functional testing including tests when loaded. For this purpose, we have built modern testing laboratories enabling us to test every flameproof electric motor, transformer and contactor set under load.

When handing over a complete delivery to our customers we always pay full attention to the assembly, equipment commissioning and thorough training of the operating staff.

Equipments produced by Hansen Electric are working in many countries, such as Czech Republic, Russia, Ukraine, Kazakhstan, Turkey, Mexico, Poland, Slovakia, Germany, Belarus, South Africa, Vietnam, Iran, Bosnia and Herzegovina, Slovenia and others.

Qualified employees, continuous product innovation and the application of state of the art technologies provide Hansen Electric customers with a guarantee of high quality partnership.

TRANSFORMER SETS

6 – 17

The transformer set is determined to transform high voltage, power supply and protection with possibility switching of three-phase mining electrical equipment and protection of a supply network.

LOAD CENTERS

18 – 27

The load center is determined for remote switching, controlling and protection of three-phase mining electrical equipment with possibility supply lighting and other equipment.

SOFT STARTS FREQUENCY INVERTORS

28 – 31

Equipment is determined for control soft starting, soft run-out of three-phase asynchronous electric motors with squirrel cage.

CIRCUIT BREAKERS DISTRIBUTION FIELDS

32 – 33

Equipment is determined for switching and protection of three-phase mining electrical equipment or for switching and protection of a mining supply network.

INTRINSICALLY SAFE CONTROL SYSTEMS

34 – 35

A microprocessor control system designed for central control of conveying in underground, programming of mining excavating technologies with speech communication, monitoring and the visualization.

LIGHT FITTINGS

36 – 37

Light fitting is determined to illuminate the working face of underground mines.

ELECTRIC MOTORS AND GENERATORS

38 – 39

Production and repairs electric motors up to 6kV, repairs and manufactures new generators of power outputs up to 10MW.

VACUUM CONTACTORS

40 – 41

An electromechanically operated device determined for frequent switching of exclusively alternating current circuits up to 1200V in the range of closing and breaking currents corresponding to AC4 category.

FLAMEPROOF TRANSFORMER SET TN6/.... – P30

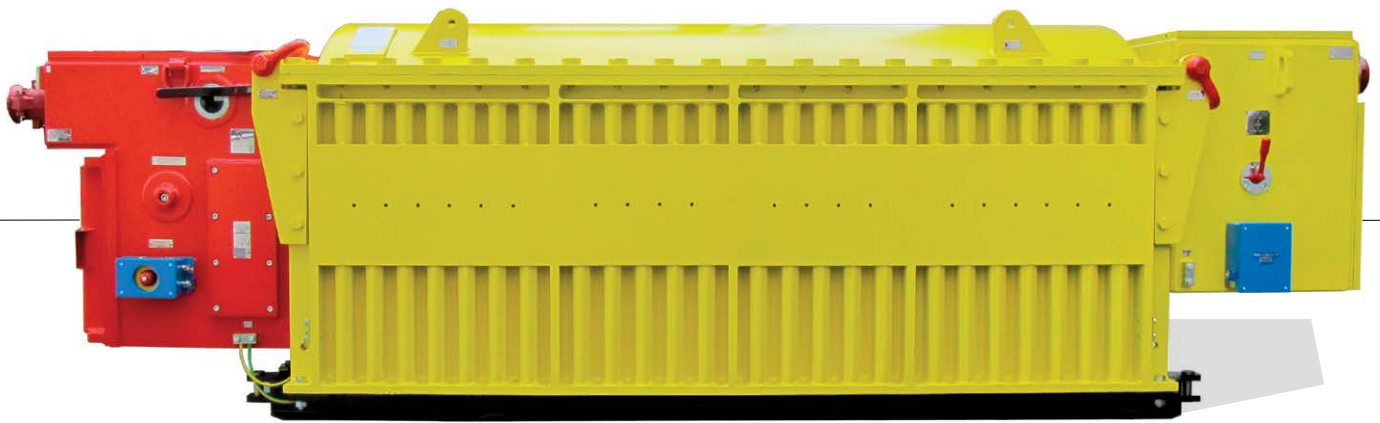

The Transformer Set is intended to transform High Voltage to low voltage, power supply and protection of three-phase electrical devices or electric power supply and protection of a supply network.

The Transformer Set has got protection against explosion $\text{Ex db [ia Ma] I Mb}$ and complies with technical requirements for devices determined for use in potentially explosive atmospheres according to Directive 2014/34/EU. The product also complies with technical requirements EN 60079-0, EN 60079-1 and EN 60079-11.

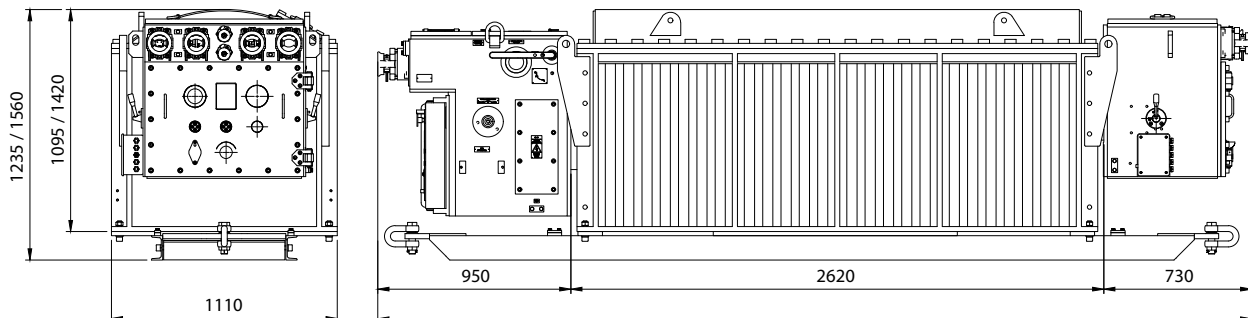

Electric circuits provide power outlet independently with:

- off-switching at short-circuit or overloads and their signalling
- on the trip short circuit must be manually reset
- blocking the switching in case the reduction of isolation resistance of power outlet is less than 50 (100)k Ω and equipment signalling
- blocking the switching in case the protective conductor resistance exceeds 80 Ω and equipment signalling
- off-switching in case the reduction of isolation resistance of power outlet is less than 30 (60)k Ω and equipment signalling
- on the trip earth fault leakage must be manually reset

Low voltage part SN40 can be equipped with two circuit breakers 630A, with 2 outputs from each. Inside is also installed LCD display for operating and faulty conditions, measured quantities, it also stores data and provides transmission of data between connected systems.

TECHNICAL DATA

Technical parameters of primary part SN6	
Nominal voltage	according to requirements from 3300VAC to 6300VAC, 50Hz or 60Hz
Nominal current	according to power output max. 250A
Nominal short-circuit power	100MVA at 6kV
Nominal off-switching short-circuit current	10kA at 7,2kV
Off-switching ability, top value	25kA
Short-circuit resistance, effective value	10kA (3s)
Time for off-switching	30÷55ms
Marking	Ex d I Mb
Total weight	850kg

Technical parameters of High Voltage transformer	
Version	dry three-phase transformer
Power output	630/800/1000/1250/1400/1500kVA
Nominal primary voltage	according to requirements from 3300VAC to 6300VAC
Nominal secondary voltage	according to requirements from 400VAC to 1200VAC
Junctions of primary winding	±5%
Frequency	50Hz or 60Hz
Connection	Yyn0 or Dyn5 or Dyn11
Impedance ek	from 4 to 5%
Type of cooling	using air (ANAN)
Class of insulated winding	H (200°C)
Marking	Ex d I Mb
Total weight (including transformer and enclosure)	4560/5160/5660/6410/6710/7230kg
Weight of transport chassis	390kg

Technical parameters of secondary part SN40	
Nominal voltage	according to requirements from 400VAC to 1200VAC, 50Hz or 60Hz
Total nominal current	according to power max. 800A
Maximum number of power outlets	4
Maximum current of an outlet	400A
Marking	Ex d [ia Ma] I Mb
Total weight	620kg

FLAMEPROOF TRANSFORMER SET TN6/.... – P31



The Transformer Set is intended to transform High Voltage to low voltage, power supply and protection of three-phase electrical devices or electric power supply and protection of a supply network.

The Transformer Set has got protection against explosion $\text{Ex I M2(M1) Ex db [ia Ma] I Mb}$. The product complies with technical requirements for devices determined for use in potentially explosive atmospheres according to Directive 2014/34/EU. The product also complies with technical requirements EN 60079-0, EN 60079-1 and EN 60079-11.

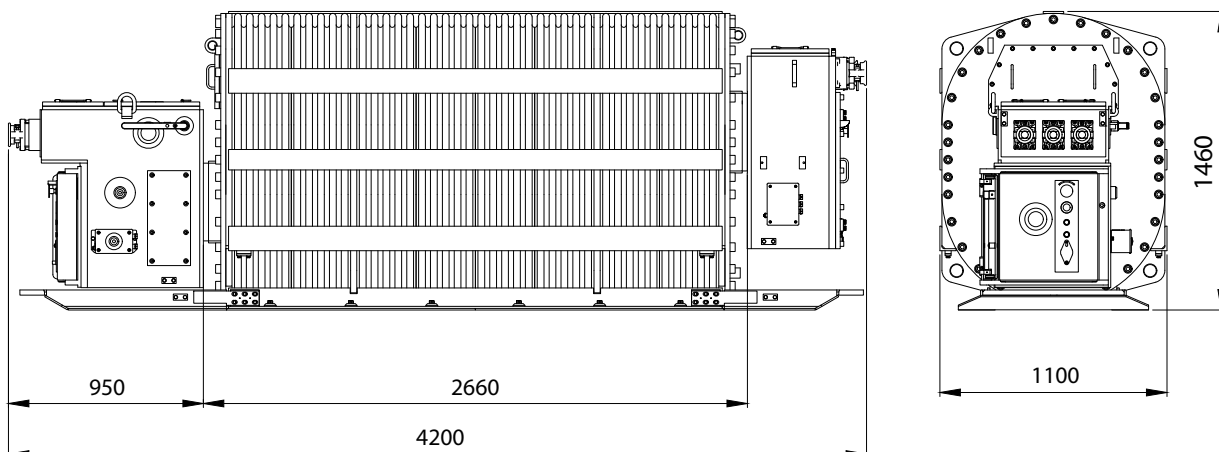

Electric circuits provide power outlet independently with:

- off-switching at short-circuit or overloads and their signalling
- on the trip short circuit must be manually reset
- blocking the switching in case the reduction of isolation resistance of power outlet is less than 50 (100)k Ω and equipment signalling
- blocking the switching in case the protective conductor resistance exceeds 80 Ω and equipment signalling
- off-switching in case the reduction of isolation resistance of power outlet is less than 30 (60)k Ω and equipment signalling
- on the trip earth fault leakage must be manually reset

LCD display operating and faulty conditions, measured quantities, it also stores data and provides transmission of data between connected systems.

TECHNICAL DATA

Technical parameters of primary part SN6	
Nominal voltage	according to requirements from 3300VAC to 6300VAC, 50Hz or 60 Hz
Nominal current	according to power output max. 250A
Nominal short-circuit power	100MVA at 6kV
Nominal off-switching short-circuit current	10kA at 7,2kV
Off-switching ability, top value	25kA
Short-circuit resistance, effective value	10kA (3s)
Time for off-switching	30÷55ms
Marking	Ex d I Mb
Total weight	850kg

Technical parameters of High Voltage transformer	
Version	dry three-phase transformer
Power output	630/800/1000/1250/1400/1500kVA
Nominal primary voltage	according to requirements from 3300VAC to 6300VAC
Nominal secondary voltage	according to requirements from 400VAC to 1200VAC
Junctions of primary winding	$\pm 2 \times 2,5\%$
Frequency	50Hz or 60Hz
Connection	Yyn0 or Dyn5 or Dyn11
Impedance ek	from 4 to 5%
Type of cooling	using air (ANAN)
Class of insulated winding	H (200°C)
Marking	Ex d I Mb
Total weight (including transformer and enclosure)	4560/5160/5660/6410/6710/7230kg
Weight of transport chassis	390kg

Technical parameters of secondary part SN5	
Nominal voltage	according to requirements from 400VAC to 1200VAC, 50Hz or 60Hz
Total nominal current	according to power max. 721,7A
Maximum number of power outlets	3
Maximum current of an outlet	345A
Auxiliary output 230V 50Hz	300VA
Auxiliary output 42V 50Hz	100VA
Marking	Ex d [ia Ma] I Mb
Total weight	530kg

FLAMEPROOF TRANSFORMER SET TN6/.... P6



The Transformer Set is intended to transform High Voltage into low voltage, power switching, control and protection of max. ten three-phase squirrel cage induction motor of mining machine drives. The mode of on-switching is controlled according to the user. Set is also equipped with a transformer with three protected and switched outputs for local lighting or as a supply for electric maintenance tools. The device can work in potentially explosive atmospheres.

The Transformer Set has got protection against explosion $\text{Ex d ib [ia Ma] I Mb}$ or $\text{Ex d ib [ia] [op is] I Mb}$. The product complies with technical requirements for devices determined for use in potentially explosive atmospheres according to Directive 2014/34/EU. The product also complies with technical requirements EN 60079-0, EN 60079-1, EN 60079-11 and event. EN 60079-28.

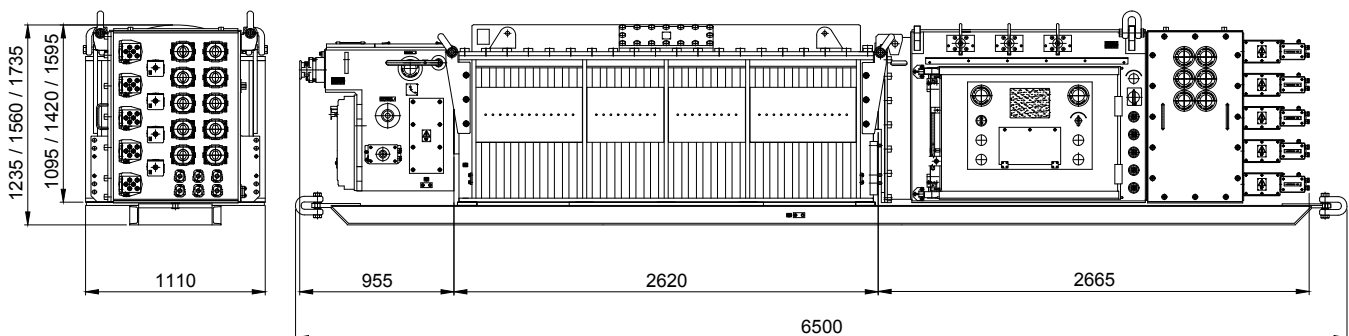

The High Voltage part of the transformer set is among others equipped with pole earthing isolator, overload protection and breaking contactor.

Electric circuits of low voltage part provide power outlet independently with:

- off-switching at short-circuit and short-circuit signalling
- protection from thermal effects of overloads and signalling of overloads
- off-switching in case the phase fall-out and in case the asymmetry of phases and equipment signalling
- off switching in case non-permissible temperature increase of electric motor
- blocking the switching in case the reduction of isolation resistance of power outlet is less than 50 (100)k Ω and equipment signalling
- off-switching in case the reduction of isolation resistance of power outlet is less than 15k Ω and equipment signalling
- blocking the switching in case the protective conductor resistance exceeds 50 Ω and equipment signalling

The control of particular outputs of the transformer is possible via:

- intrinsically safe circuits
- intrinsically non-flammable circuit in a power cable
- APD converters, eventually mFk

The Transformer Set is equipped by industrial PC, which serves for monitoring and parameterization of digital protections of the set, saving parameters of the protections, measuring values, operating and faulty conditions.

All the information is possible to transmit via I.S. convertors to a remote working place. The Industrial PC is equipped with I.S. keyboard, I.S. mouse and 12" screen. It is possible to add an optical output to the set which permits voice communication (VoIP) via Ethernet.

TECHNICAL DATA

Technical parameters of primary part SN6	
Nominal voltage	according to requirements from 3300VAC to 6300VAC, 50Hz or 60 Hz
Nominal current	according to power output max. 250A
Nominal short-circuit power	100MVA at 6kV
Nominal off-switching short-circuit current	10kA at 7,2kV
Off-switching ability, top value	25kA
Short-circuit resistance, effective value	10kA (3s)
Time for off-switching	30÷55ms
Type of explosion protection	Ex d I Mb
Total weight	850kg

Technical parameters of High Voltage transformer	
Version	dry three-phase transformer
Power output	1000/1250/1400/1500/1600/1750kVA
Nominal primary voltage	according to requirements from 3300VAC to 6300VAC
Nominal secondary voltage	according to requirements from 500VAC to 1200VAC
Junctions of primary winding	±5%
Frequency	50Hz or 60Hz
Connection	Yyn0 or Dyn5
Impedance ek	from 4 to 5%
Type of cooling	using air (ANAN)
Class of insulated winding	H (200°C)
Type of protection against explosion	Ex d I Mb
Total weight (including transformer and enclosure)	5660/6410/6710/7230/7160/7560kg
Weight of transport chassis	390kg

Technical parameters of secondary part SN12	
Nominal voltage	according to requirements from 500VAC to 1200VAC, 50Hz or 60Hz
Total nominal current	according to power output max. 770A
Maximum number of switched/control power outputs	10
Type of protection against explosion	Ex d ib [ia Ma] I Mb or Ex d ib [ia] [op is] I Mb
Nominal continuous current:	
- Outputs with vacuum contactor (450A)	4
- Outputs with vacuum contactor (200A)	6
- Outputs 230V/127V 50Hz (6kVA), event. 110V 60Hz (8kVA)	3
Total weight	2400kg

FLAMEPROOF TRANSFORMER SET TN6/... – P28



The Transformer Set is determined to transform High Voltage, power switching, control and protection of max. twelve three-phase squirrel cage induction motor of mining machine drives. The set is also equipped with max. two transformers, each with two protected and switched outputs for local lighting or as a supply for electric maintenance tools.

The Transformer Set has got protection against explosion $\text{Ex d ib [ia Ma] I Mb}$ or $\text{Ex db ib [ia] [op is] I Mb}$. The product complies with technical requirements for devices determined for use in potentially explosive atmospheres according to Directive 2014/34/EU (NV 116/2016 Sb.). The product also complies with technical requirements EN 60079-0, EN 60079-1, EN 60079-11 and event. EN 60079-28.

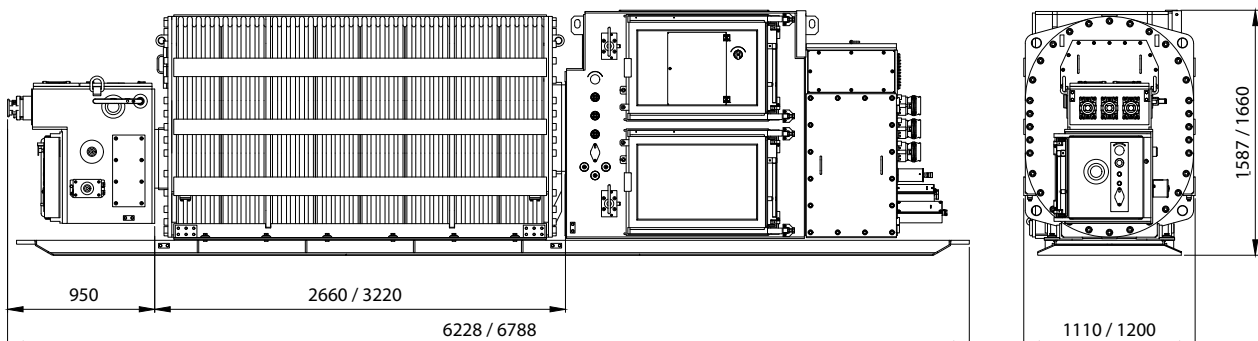

The High Voltage part of the transformer set is among others equipped with pole earthing isolator, overload protection and breaking contactor.

Electric circuits of low voltage part provide power outlet independently with:

- off-switching at short-circuit and short-circuit signalling
- protection from thermal effects of overloads and signalling of overloads
- off-switching in case the phase fall-out and in case the asymmetry of phases and equipment signalling
- off switching in case non-permissible temperature increase of electric motor
- blocking the switching in case the reduction of isolation resistance of power outlet is less than 50 (100)k Ω and equipment signalling
- off-switching in case the reduction of isolation resistance of power outlet is less than 15k Ω and equipment signalling
- blocking the switching in case the protective conductor resistance exceeds 50 Ω and equipment signalling

The Transformer Set is equipped by industrial PC, which serves for monitoring and parameterization of digital protections of the set, saving parameters of the protections, measuring values, operating and faulty conditions. All the information is possible to transmit via I.S. convertors to a remote working place.

The Industrial PC is equipped with I.S. keyboard, I.S. mouse and 12" screen. It is possible to add an optical output to the set which permits voice communication (VoIP) via Ethernet.

TECHNICAL DATA

Technical parameters of primary part SN6	
Nominal voltage	according to requirements from 3300VAC to 6300VAC, 50Hz
Nominal current	according to power output max. 250A
Nominal short-circuit power	100MVA at 6kV
Nominal off-switching short-circuit current	10kA at 7,2kV
Off-switching ability, top value	25kA
Short-circuit resistance, effective value	10kA (3s)
Time for off-switching	30÷55ms
Marking	Ex d I Mb
Total weight	850kg

Technical parameters of High Voltage transformer	
Version	dry three-phase transformer
Power output	1000/1250/1400/1500/1600/1750/2000/2200kVA
Nominal primary voltage	according to requirements from 3300VAC to 6300VAC
Nominal secondary voltage	according to requirements from 500VAC to 1200VAC
Junctions of primary winding	±5%
Frequency	50Hz or 60Hz
Connection	Yyn0 or Dyn5
Impedance ek	from 4 to 5%
Type of cooling	using air (ANAN)
Class of insulated winding	H (200°C)
Marking	Ex db I Mb
Total weight (including transformer and enclosure)	6080/6280/6980/7180/7480/8540/9340/10140kg
Weight of transport chassis	390kg

Technical parameters of secondary part SN42	
Nominal voltage	according to requirements from 500VAC to 1200VAC, 50Hz or 60Hz
Total nominal current	according to power output max.
Marking	Ex d ib [ia Ma] I Mb
Maximum number of power outputs	12
Nominal current of power outputs (example with max. 6 module positions):	
- 2x module MS6R with 4 vacuum contactors 450A	2 reversible outputs
- 3x module MS5 with 4 vacuum contactors 200A	2 reversible outputs
- 1x module MT4 – output 230V/127V 50Hz (5kVA)	2 outputs
Total weight	3500kg

FLAMEPROOF TRANSFORMER SET TN6/.... – P5

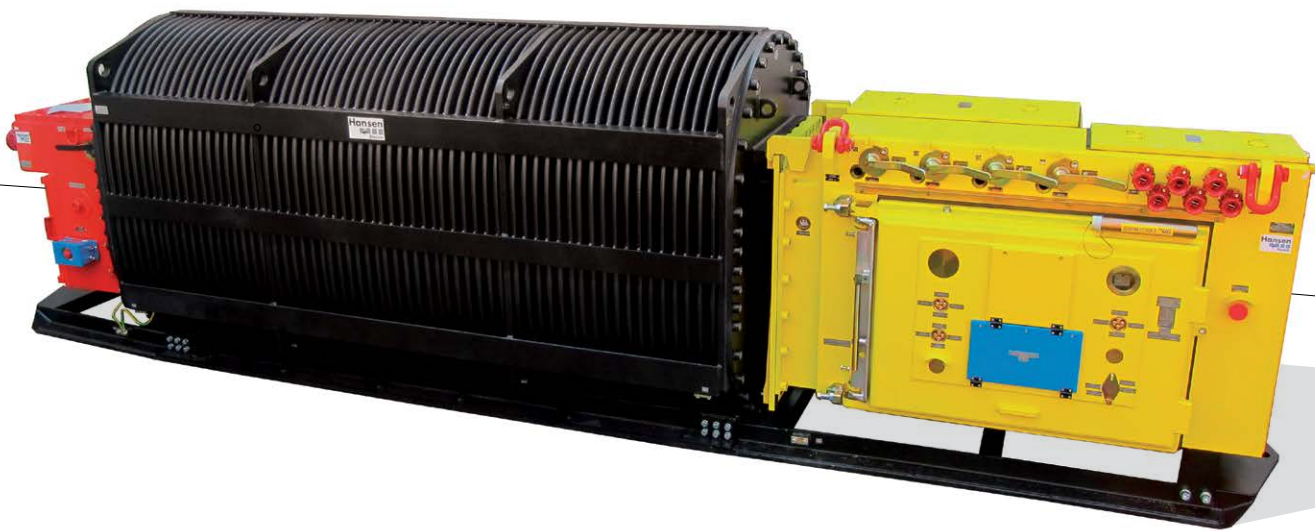

The Transformer Set is intended for transformation of High Voltage, for power switching, control and protection of three-phase squirrel cage motors of mining machine drives with reversing option or eventually for supply and protection of power supply mains 3/PE AC 3300V 50Hz/IT and for supply of lighting.

The Transformer Set has got a protection against explosion $\text{Ex I M2(M1) Ex d ib [ia Ma] I Mb}$. The product complies with technical requirements for devices determined for use in potentially explosive atmospheres according to Directive 2014/34/EU. The product also complies with technical requirements EN 60079-0, EN 60079-1 and EN 60079-11.

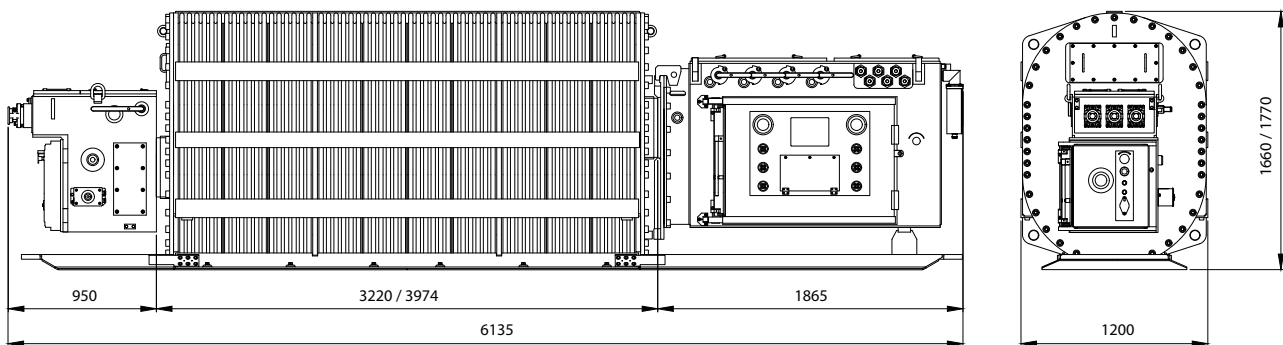

The High Voltage part of the transformer set is among others equipped with pole earthing isolator, overload protection and breaking contactor.

Electric circuits of power centre secure the following for each power outlet independently:

- off-switching at short-circuit and short-circuit indication
- protection from thermal effects of overloads and overloads indication
- off-switching at the event of phase failure and phase asymmetry, and tripping indication
- blocking of on-switching at the event of power outlets insulation resistance decreasing under 220kΩ and tripping indication
- power supply off-switching at the event of power outlets insulation resistance decreasing under 85kΩ and tripping indication
- blocking the operation at the event of protective conductor increasing over 50Ω and tripping indication
- Control of insulated mode of outlet cable before on-switching using HV tester

The Transformer Set is equipped with max. 4 positions for quick changing module system on the secondary side. The transformer set is equipped by industrial PC, which serves for monitoring and parameterization of digital protections of the set, saving parameters of the protections, measuring

values, operating and faulty conditions. All the information is possible to transmit via I.S. convertors to a remote working place. The Industrial PC is equipped with I.S. keyboard, I.S. mouse and 12" screen.

TECHNICAL DATA

Technical parameters of primary part SN6	
Nominal voltage	according to requirements from 6000VAC to 6300VAC, 50Hz
Nominal current	according to power output max. 250A
Nominal short-circuit power	100MVA at 6kV
Nominal off-switching short-circuit current	10kA at 7,2kV
Off-switching ability, top value	25kA
Short-circuit resistance, effective value	10kA (3s)
Time for off-switching	30÷55ms
Marking	Ex d I Mb
Total weight	850kg

Technical parameters of High Voltage transformer	
Version	dry three-phase transformer
Power output	1500/1750/2100/2500/2800/3000/3150kVA
Nominal primary voltage	according to requirements from 6000VAC to 6300VAC
Nominal secondary voltage	3300VAC
Junctions of primary winding	±5%
Frequency	50Hz
Connection	Dyn5 or Dyn11
Impedance ek	from 4 to 5%
Type of cooling	using air (ANAN)
Class of insulated winding	H (200°C)
Marking	Ex d I Mb
Total weight (including transformer and enclosure)	7060/8300/9400/11350/12060/12590/12950kg
Weight of transport chassis	390kg

Technical parameters of secondary part SN12	
Nominal voltage	3300VAC, 50Hz
Total nominal current	according to power output max. 525A
Maximum number of power outputs	4
Maximum current of power output	450A
Output for lightning	5,2/9,4A
Marking	Ex d ib [ia Ma] I Mb
Total weight	2200kg

FLAMEPROOF TRANSFORMER SET TN6/.... – P11

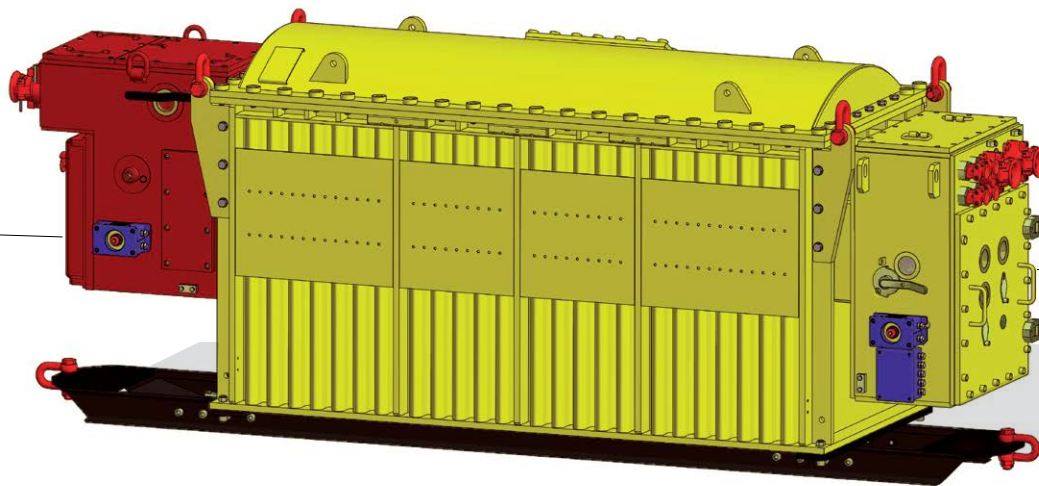

The Transformer Set is intended for transformation of High Voltage, power supply, control and protection of three-phase electric devices or eventually protection of power supply mains 3/ PE AC 3300V 50Hz/IT.

The Transformer Set has got protection against explosion $\text{Ex I M2(M1) Ex db [ia Ma] I Mb}$ or $\text{Ex I M2(M1) Ex db [ia op is Ma] I Mb}$. The product complies with technical requirements for devices determined for use in potentially explosive atmospheres according to Directive 2014/34/EU. The product also complies with technical requirements EN 60079-0, EN 60079-1, EN 60079-11 and event. EN 60079-28.

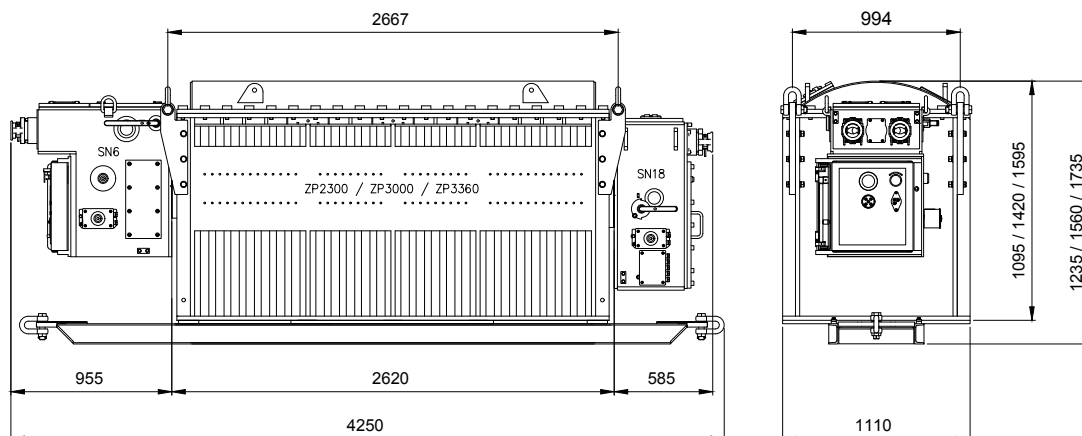

The High Voltage part of the transformer set is among others equipped with pole earthing isolator, overload protection and breaking contactor.

Electric circuits provide power outlet independently with:

- off-switching at short-circuit and short-circuit signalling
- protection from thermal effects of overloads and signalling of overloads
- off-switching in case the phase fall-out and in case the asymmetry of phases and equipment signalling
- blocking the switching in case the reduction of isolation resistance of power outlet is less than 220k Ω and equipment signalling
- off-switching in case the reduction of isolation resistance of power outlet is less than 85k Ω and equipment signalling
- blocking the switching in case the protective conductor resistance exceeds 50 Ω and equipment signalling control of the insulating state of circuit cable before on-switching using tester

TECHNICAL DATA

Technical parameters of primary part SN6	
Nominal voltage	according to requirements from 6000VAC to 6300VAC, 50Hz
Nominal current	according to power output max. 250A
Nominal short-circuit power	100MVA at 6kV
Nominal off-switching short-circuit current	10kA at 7,2kV
Off-switching ability, top value	25kA
Short-circuit resistance, effective value	10kA (3s)
Time for off-switching	30÷55ms
Marking	Ex d I Mb
Total weight	850kg

Technical parameters of High Voltage transformer	
Version	dry three-phase transformer
Power output	1500/1750/2100/2500/2800/3000/3150kVA
Nominal primary voltage	according to requirements from 6000VAC to 6300VAC
Nominal secondary voltage	3300VAC
Junctions of primary winding	±5%
Frequency	50Hz
Connection	Dyn5 or Dyn11
Impedance ek	from 4 to 5%
Type of cooling	using air (ANAN)
Class of insulated winding	H (200°C)
Marking	Ex d I Mb
Total weight (including transformer and enclosure)	7060/8300/8400kg
Weight of transport chassis	390kg

Technical parameters of secondary part SN18	
Nominal voltage	3300VAC, 50Hz
Total nominal current	according to power max. 367,4A
Maximum number of power outlets	2
Maximum current of an outlet	300A
Marking	Ex d ib [ia Ma] I Mb
Total weight	630kg

FLAMEPROOF LOAD CENTER WS – 315.*.*

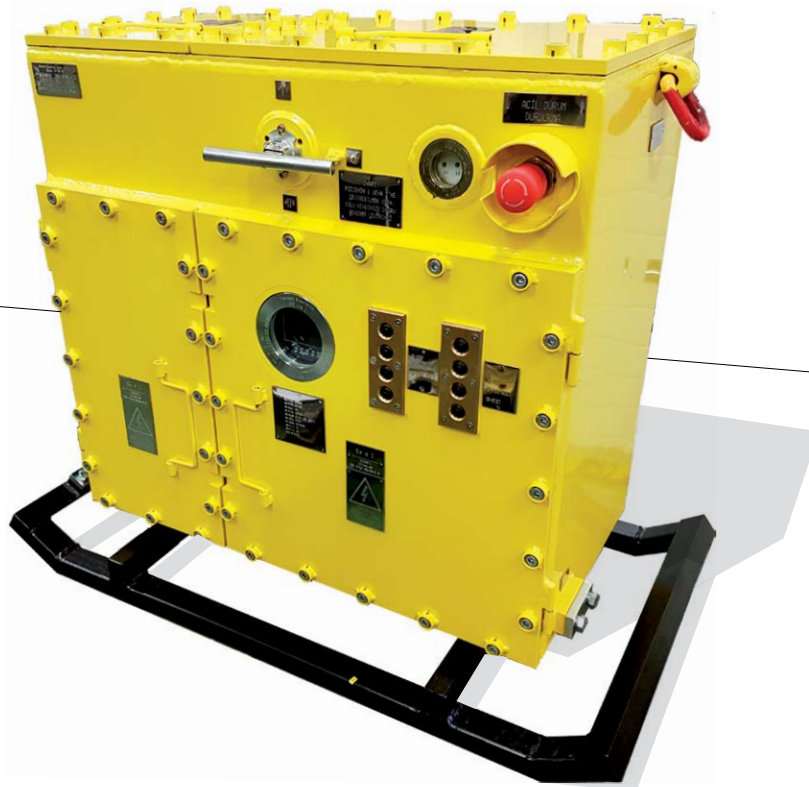

The Load Center WS-315.*.* is used to power the power electric motors built in danger explosion zones of methane and coal dust.

Its flameproof design is characterized by small dimensions and low weight, allows manual transport to the workplace. Disconnecter has the function of changing the direction of rotation of the motor (R).

The Load Center has got protected one or two main outlets and one auxiliary outlet (42V or 230V). The Auxiliary outlet can be used to power auxiliary equipment or lighting local workplace. Control of the main outlets is realized by local buttons or remote intrinsically safe circuits.

TECHNICAL DATA

Technical parameters	
Nominal supply voltage	500, 660, 1000, 1100, 1140V, 50/60Hz
Max. current	315A
Max. current of outlet	200A
Voltage of auxiliary outlet AC	42V or 230V
Power of auxiliary outlet	200 VA
Ambient temperature	0°C ≤ Ta ≤ +40°C
Level of protection	IP65
Marking of protection	Ⓔ I M2(M1) Ex db [ia Ma] I Mb Ⓔ I M2(M1) Ex db [ia op is Ma] I Mb
Dimensions	650 x 350 x 650 mm

SPECIFICATIONS

Marking:

- Load CenterWS – 315,*A,*B,*C,*D

Option (*A):

315 (200, 80) – nominal current of first outlet
R – reversing outlet

Option (*B):

200 (80) – nominal current of second outlet
blank space – without a second outlet

Option (*C):

A – with isolator
B – with circuit breaker

Option (*D):

A – for IT
B – for IT+TN
C – for TN

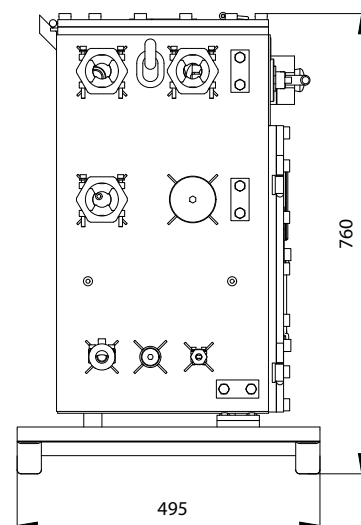
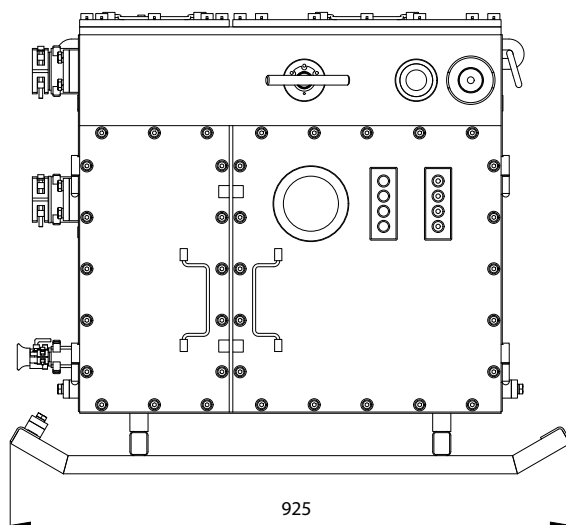

FLAMEPROOF LOAD CENTER SN1



The Load Center SN1 is intended for switching and protection of maximum four three-phase asynchronous electric squirrel cage motors with reversing option.

The product complies with technical requirements for devices determined for use in potentially explosive atmospheres of mines according to Directive 2014/34/EU. It is designed for use in the supply mains 3/PE AC 500/660/1000/1100V/1140V 50Hz/IT.

Power and control circuits can be connected as:

- controlled individually
- reversing connection (after internal connection modification)
- connection for switching dual speed electromotor (after internal connection modification)

Each outlet is equipped with an integrated motor relay RMI3, which integrates these protections for the motor:

- earth leakage relay prior to on switching
- pilot circuit monitor
- motor overhear (posistor)
- short circuit, overload, phase failure + timing relay

Description and equipment

The Load Center SN1 is made as a flameproof enclosure and consists of three welded-design boxes. In the middle there is the main instrument box, which is made as a steel enclosure, the door is provided with a flap lock. It is furnished with input and output connection boxes for connection to external circuits. These boxes are screwed on both sides of the main instrument box. Internal area of the instrument box is accessible from the front side after opening of a flap lock, there is change-over isolator 1200V/500A in the upper part, vacuum contactors and fuses. In the flap lock door there is a sight glass PZ110 behind which there is a display ID1 for monitoring of contactors operation states, their control circuits, shutdown of protections and switch on of control converters. Display ID1 further enables data archiving and data transfer among consecutively connected systems.

The set is also equipped with a transformer of output of max. 800VA and with output voltage of 127 or 230V for the supply of lighting and signalling equipment.

Connecting compartment

The inlet supply cables (max. 4 pcs) are connected to the bus-bar box on the right-hand side of the set. To the connecting terminals of each power bushing wires having a diameter of up to 120 mm² can be connected. The bus-bar unit is accessible after dismounting the lid. Through the inspection hole of the lid we can see an analogous voltmeter indicating the presence of the networks supply voltage. The bus-bar box on the left-hand side of the set covers terminals of power bushings for interconnection of two to four output cables of max. cross-section of conductors 95 mm². Besides this the box is equipped with terminals for control and watching circuits.

Safety lock

The control of the quick release door is mechanically interconnected by means an internal lock with control shaft of the power changeover isolator in such a way that it can be opened only in case the power changeover isolator is in the off position.

TECHNICAL DATA

Operation parameters	
Rated supply voltage	3 AC 500/660/1000/1100V/1140V; 50Hz
Rated current	450A
Marking	Ⓔ I M2(M1) Ex db [ia Ma] I Mb
Number of power outlets	max. 4
Protection	IP54
Weight	740kg

Vacuum contactors (HR-VS80)	
Rated operational an insulation voltage	1200V
Rated current	80A

Vacuum contactors (HR-VS200)	
Rated operational an insulation voltage	1200V
Rated current	200A

Vacuum contactors (HR-VS3/HR-VS4/450)	
Rated operational an insulation voltage	1200V
Rated current	315A/400/450A

Current range (determined by installed electronic protection RMI3 and converters corresponding to it)	
Dependent protection (a-release)	33,3 – 400A without amplification (3,3 – 40A with amplification)
Independent protection (n-release)	3 – 12In

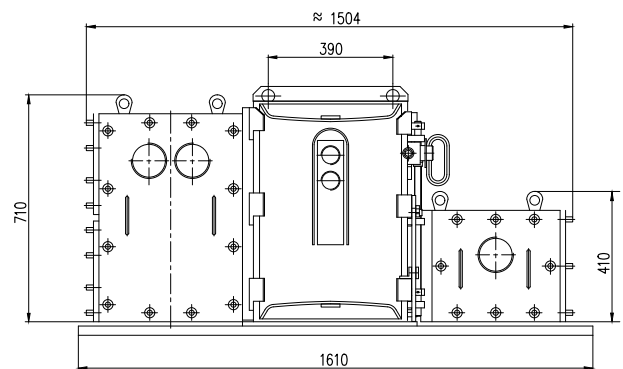
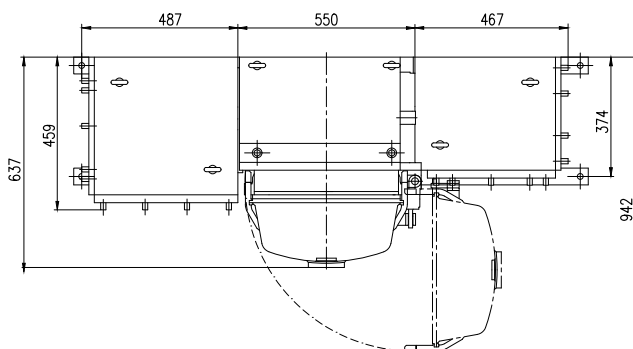

FLAMEPROOF LOAD CENTER SN2



The Load Center SN2 is intended for the switching and protection of maximum six three-phase asynchronous electric squirrel cage motors with reversing option.

The product complies with technical requirements or devices determined for use in potentially explosive atmospheres of mines according to Directive 2014/34/EU. It is designed for use in the supply mains 3/PE AC 500/660/1000/1100V/1140V 50Hz/IT.

The device is manufactured in different designs, which differ in connection of the power part. The control part can be modified as per the requirements of the customer.

Contactor connection

The Load Center is divided into two separate branches. Each of these branches is equipped with a change-over isolator 1200V/500A and a set of fuses. Under the power fuses there are 4-8 pcs of vacuum contactors.

Power and control circuits can be connected as:

- controlled individually
- reversing connection
- connection for switching dual speed electromotor

Each outlet is equipped with an integrated motor relay RMI3, which integrates these protections for the motor:

- earth leakage relay prior to on switching
- pilot circuit monitor
- motor overheat (posistor)
- short circuit, overload, phase failure + timing relay

Description and equipment

The instrumental compartment of the load center is executed as a flameproof welded steel enclosure equipped with a quick release door. In the flap lock door in the left position there is an inspection window PZ110 behind which there is ID1 display for monitoring of contactors operation states, their control circuits, shutoff of protections and switch on of control converters. Display ID1 further enables data archiving and data transfer among consecutively connected systems. In the right position there is a brass head with three pushbuttons for display control mounted through a reducer. The protection relays are located in the control panel on the internal door space and they are easily accessible.

The set is also equipped with a transformer of the output of max. 800VA and with an output voltage of 127 or 230V for the supply of lighting and signalling equipment.

Connecting compartment

The inlet supply cables (max. 4 pcs) are connected to the bus-bar box on the right-hand side of the set. To the connecting terminals of each power bushing wires having a diameter of up to 120 mm² can be connected. The bus-bar unit is accessible after dismounting the lid. Through the inspection hole of the lid we can see an analogous voltmeter indicating the presence of the networks supply voltage. The bus-bar box on the left-hand side of the set covers terminals of power bushings for interconnection of two to six output cables of max. cross-section of conductors 120 mm². Besides this the box is equipped with terminals for control and watching circuits.

Safety lock

The control of quick-release door is mechanically interconnected by means of internal lock with control shaft of the power changeover isolator in such a way that it can be opened only in case the power changeover isolator is in the off position.

TECHNICAL DATA

Operation parameters	
Rated supply voltage	3 AC 500/660/1000/1100V/1140V; 50Hz
Total rated current	800A
Marking	Ⓔ I M2(M1) Ex db [ia Ma] I Mb
Number of power outlets	max. 6
Protection	IP54
Weight	1450kg

Vacuum contactors (HR-VS80, HR-VS200, HR-VS3, HR-VS4/450)	
Rated operational an insulation voltage	1200V
Rated current	80A/200A/315A/400A/450A

Current range (determined by installed electronic protection RMI3 and converters corresponding to it)	
Dependent protection (a-equipment)	33,3 – 400A without amplification (3,3 – 40A with amplification)
Independent protection (n-equipment)	3 – 12xIn

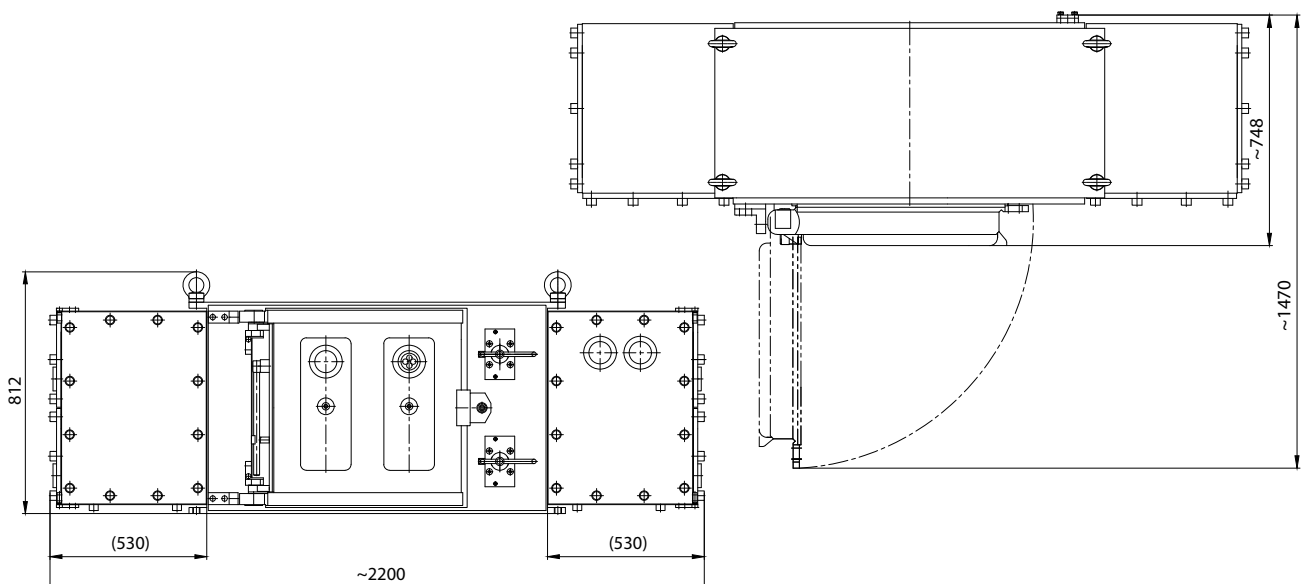

FLAMEPROOF LOAD CENTER SN43



The Load Center SN43 serves as remote power switching, controlling and protection of three-phase asynchronous electromotors and supplying of lightning in potentially explosive atmospheres of mines. It is classified as the equipment of group I category M2.

The Load Center has got protection against explosion $\text{Ex I M2(M1) Ex db ib [ia Ma] I Mb}$ or $\text{Ex I M2(M1) Ex db ib [ia op is Ma] I Mb}$. This product complies with technical requirements for devices determined for use in potentially explosive atmospheres of mines according to Directive 2014/34/EU (NV 116/2016 Coll.). It also complies with requirements of EN 60079-0, EN 60079-1 and EN 60079-11.

Electrical circuits of a load center provide independently for each power outlet:

- shutdown during short-circuit and short-circuit indication
- protection from thermal effects of overloads and overloads indication
- shutdown at phase failure and phase asymmetry and tripping indication
- switch off by thermistor relay when the temperature of electromotor increases above-allowed limit
- blocking of switching on while decreasing insulating resistance of power outlets under 100kΩ and tripping indication
- shutdown of supplying while decreasing insulating resistance of power outlets under 50kΩ and tripping indication
- blocking the operation at the event of protective conductor increasing over 50Ω and tripping indication

The Load Center is equipped with an industrial PC which serves for monitoring and parameterization of digital protections of the set, saving parameters of the protections, measuring values, operating and faulty conditions. All the

information is possible to transmit by I.S. separators to a remote working place. The Industrial PC is equipped with I.S. keyboard, I.S. mouse and 12" screen. It is possible to add optical output and voice communication (VoIP) via Ethernet.

TECHNICAL DATA

Technical parameters	
Nominal voltage	3 AC 550/1000 - 660/1140V, 50Hz
Nominal continuous current	900A
Number of switched/fused power outlets	6 (4x 400A, 2x 12A lighting)
Type of protection against explosion	I M2(M1) Ex db ib [ia Ma] I Mb or Ex db ib [ia op is Ma] I Mb
Nominal continuous current of power outlets:	
4 outlets with vacuum contactor	max. 4x 350A/200A
2 outlets 127V/230V	5κVA
Total weight	3000kg

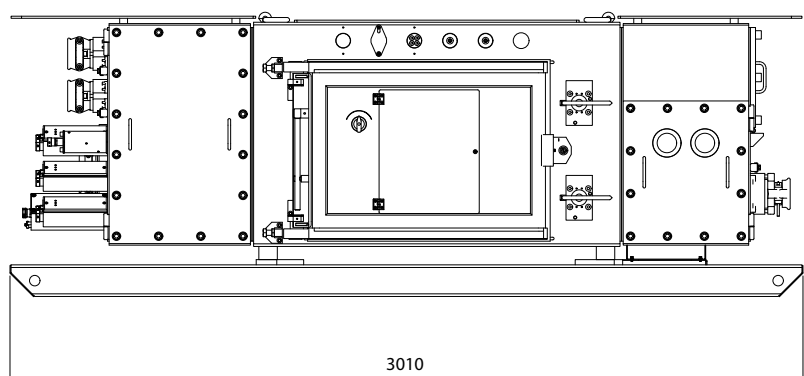
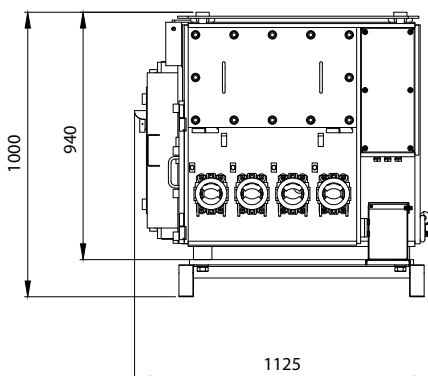

FLAMEPROOF LOAD CENTER SN20

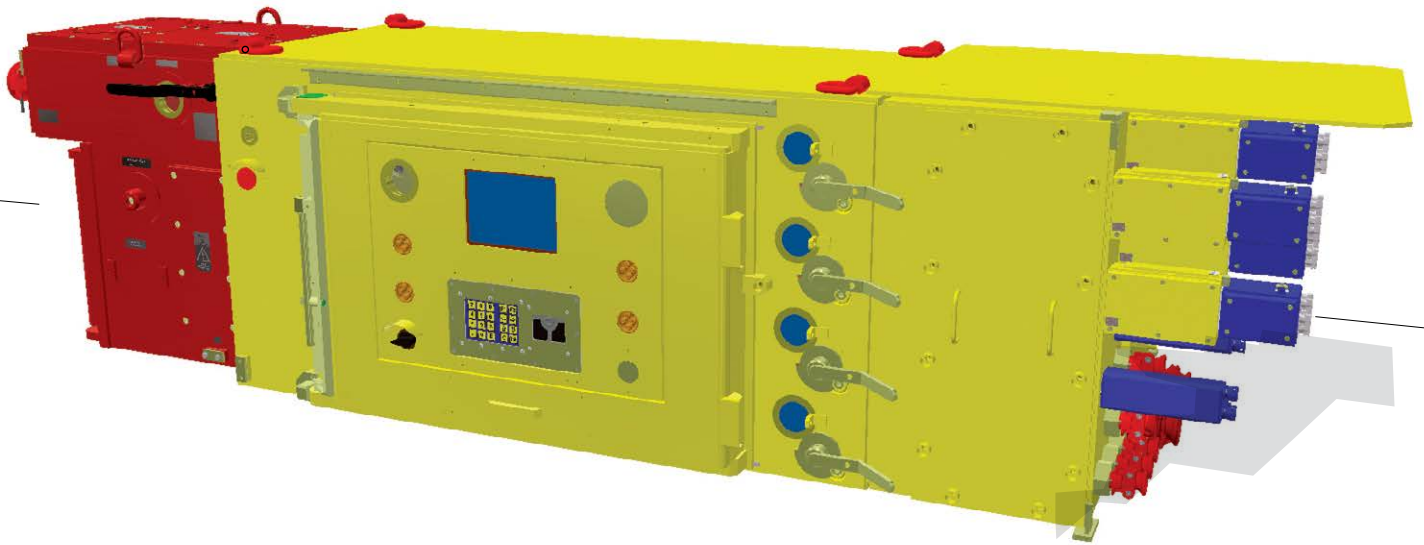

The Load Center SN20 is determined for power switching, control and protection of up to four explosion-proof three-phase asynchronous electric motors of mining machinery drives and feeding of lightning. The product complies with technical requirements for devices determined for use in potentially explosive atmospheres of mines. It is classified as being intrinsically safe equipment group I category M2. This device is designed for use in the supply mains 3/PE AC 3300V 50Hz/IT.

The Load Center has got protection $\text{Ex db ib [ia Ma] Mb}$. The product complies with technical requirements for devices determined for use in potentially explosive atmospheres of mines according to Directive 2014/34/EU. It also complies with technical requirements according to EN 60079-0, EN 60079-1, EN 60079-11.

Electrical circuits of a low voltage part provide independently for each power outlet:

- shutdown during circuit and signaling circuit
- protection against thermal effects and signalling overcurrents
- shutdown at phase failure and phase asymmetry and signalling equipment
- blocking of switching on while decreasing insulating resistance of power outlets and signalling equipment
- shutdown of feeding while decreasing insulating resistance of power outlets and signalling equipment
- blocking while interrupting or increasing resistance of grounding circuit more than 50Ω and signalling equipment
- supervising condition of the insulation of the cables while they are switched off by integrated tester of direct voltage 3kV
- supervising condition of the cables while they are switched on by relay UP6

The set is equipped with an industrial PC which is designated for monitoring and parametrization of digital protection of the set, storing parameters of protection, measured values, operating conditions and faults. All the information is possible to transmit by I.S. converters to a distant place.

The Industrial PC is equipped with I.S. keyboard, I.S. mouse and 12" screen. It is possible to add optical output and voice communication (VoIP) via Ethernet.

The set of contactors SN20 is manufactured in three versions:

Version	Number of outputs 3300V	Number of outputs 230V/127V
P02.1	4	-
P02.1/01	3	1
P02.1/02	2	2

TECHNICAL DATA

Operation parameters	
Rated supply voltage	3 AC 3300 V, 50÷60 Hz
Total rated current	315A
Number of power outputs 3AC 3300V	max. 4
Nominal continuous current of power outputs	250A
Number of outputs 2AC 230V/127V – 5kVA	max. 2
Nominal continuous current of outputs	21/39A
Weight	3450kg

Auxiliary voltage and control voltage	
2AC 230V/127V – 1,2kVA	5,2/9,4A
2AC 42V	50VA

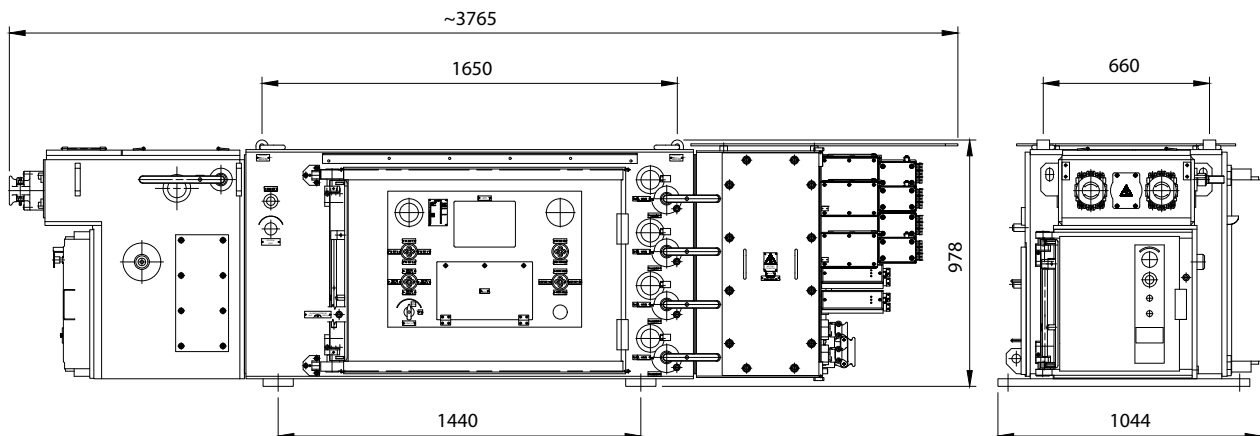

FLAMEPROOF SET FOR SOFT START EZO1, EZO2

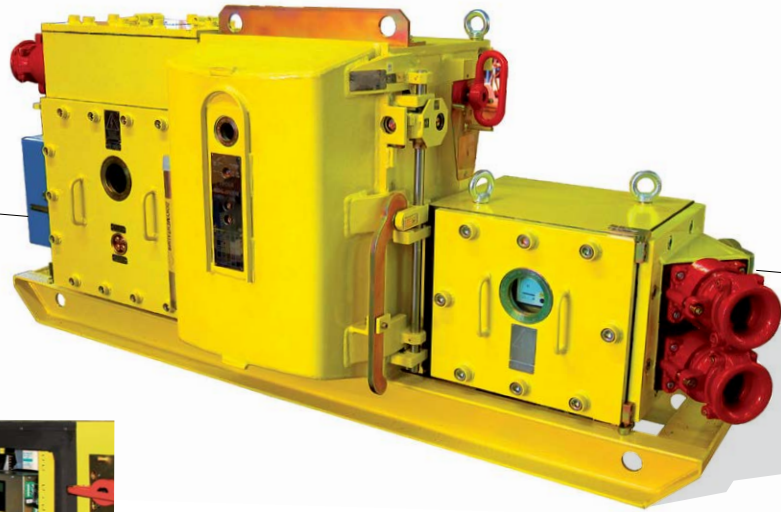

EZO1



EZO2

Individual working parameters of the drive, e.g. starting time, maximum starting current, DC braking, braking current, maximum short-circuit current and nominal current of the motor are set up by means of a keyboard or using a PC via series circuit wiring. They are stored in the microprocessor memory even after their disconnecting from the supply mains. The control microprocessor also carries out complete diagnostics of operational and emergency states appearing on the display. The emergency states are stored in an energetically independent microprocessor memory.

It is a Load Center fitted with two thyristor regulators which are controlled by microprocessors and used to control soft starting, soft run-out and DC braking of asynchronous squirrel cage electric motors. After the set-up starting time the contactor closes a BYPASS which serves as a bridge over the thyristor unit and puts it out of operation. After that the apparatus performs the role of a load center.

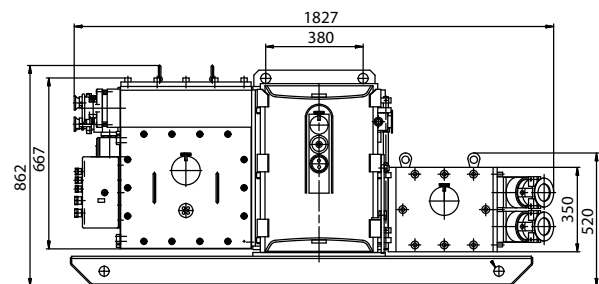

EZO2

EZO1

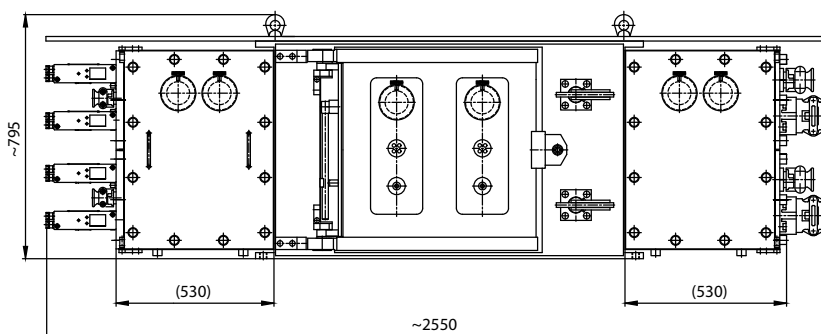

Main advantages of the set use:

- decrease in mechanical load of drives and removal of mechanical impulses resulting in longer lifetime of the mechanical units
- when used with belt conveyors no slipping between the belt and driving drum of the conveyor – longer lifetime of belts
- operation of complex starting conveyor drives operating with single-speed electric motors and without hydraulic clutches – reducing initial costs
- possibility of DC braking of conveyor drives electric motors – reducing wear of mechanical brakes of conveyors, removing mechanical impulses
- reduction of excessive voltage oscillating in the supply mains at the start

The device contains the following kinds of protection:

- control by means of microprocessor for protection:
 - maximum current protection (short-circuit) and protection against overload
 - monitoring of supply voltage limit values, current asymmetry and supply voltage phase drop-out
 - monitoring drive revolutions in its individual operational modes
- for insulation control of all external circuits
- protection for earthing conductor control
- protection for control of tolerable temperature of electric motors that are supply

The device also enables:

- limitation of maximum starting and braking current
- continuous measuring and displaying of output currents, supply voltage, temperature of cooling system with power output units, air temperature inside the load center, drive revolutions on the display
- testing thyristors, testing short circuit, testing overload
- control of mechanical brake of belt conveyor
- combination with automatics of conveyor transport APD1
- cascade connection arrangement of several starters for realization of soft starting of belt conveyor with several drives
- communication (visual) with a remote working place (e.g. PC) by means of series circuit wiring

Technical description

EZSO1 enables feeding electric motors with total power output 4x 315kW or 2x 630kW (1000/1140V)/4x 160kW or 2x 315kW (500/660V). EZSO2 enables feeding electric motors with total power output 2x 315kW or 1x 630kW (1000/1140V)/2x 160kW or 1x 315kW (500/660V). The device enables the reversing of the drive and does not require tree use of other auxiliary contactors. If nec-

essary, it is possible to run the device only in the BY-PASS mode (thyristor unit bridged with a contractor). The product complies with technical requirements for devices determined for use in potentially explosive atmospheres of mines according to Directive 2014/34/EU. It is classified as being intrinsically safe equipment group I category M2.

TECHNICAL DATA

Type	EZSO1			EZSO2		
Nominal supply voltage	500/1000V 50Hz or 660/1140V 50Hz					
Outputs	Current	Voltage of the motor		Current	Voltage of the motor	
	500/660V	1000/1140V		500/660V	1000/1140V	
Max.	4x200A	4x160kW	4x315kW	2x200A	2x160kW	2x315kW
Or max.	2x400A	2x315kW	2x630kW	1x400A	1x315kW	1x630kW
Vacuum contactor type	4x HR-VS4 (400A)			2x HR-VS4 (400A)		
Starting	- starting time					
	- boost (initial current jump)					
DC braking - DC braking time	- boost (initial current rise)					
	- boost (initial current rise)					
Max. current limitation (starting, break)	4x1500A or 2x3000A			2x1000A or 1x2000A		
Explosion-proof equipment marking	Ex M2 Ex d [ib] I Mb					
Dimensions/Weight	2550 x 795 x 760 mm / 1450kg			1920 x 884 x 680 mm / 830kg		

FLAMEPROOF FREQUENCY INVERTER EZMK35



Water cooled Frequency Inverter with a pulse width modulation output voltage are produced in the explosion-proof equipment for mines.

The inverter is used for fluid control drive or speed control of three-phase asynchronous electric motors with squirrel cage, and it is particularly suitable for drives with frequent starting, braking and changes the direction of rotation. the inverter allows recovery of energy from over synchronous engine speed back to the mains.

The product meets the technical requirements for equipment intended for use in potentially explosive atmospheres in accordance with Directive 2014/34/EU.

The Frequency Inverter EZMK35 is based on a new technology – water cooled power components and it is placed in a flameproof enclosure. The Equipment has got protection against explosion $\text{Ex I M2(M1) Ex db [ia Ma] I Mb}$. The main box is made as a steel enclosure with a door provided with a flap lock. On the right side of the chassis is located a bus-bar box, common to supply inputs, output and control cables. The power of the frequency converter is placed on the construction of the water cooler.

Control circuit frequency inverters, protection and application circuits are three separate panels, allowing easy replacement. Control of frequency inverter is solved with voltage 42V, 50Hz and intrinsically safe inputs.

Application:

- pump, fan drives and other
- drives with conveyor belt speed control
- drives overhead tracks with endless rope
- rail transport with electric locomotives
- drives winches
- drives to travel mining harvesters

TECHNICAL DATA

Technical parameters	
Nominal supply voltage	3/PE AC 500-1140V 50Hz, -15% to +10%
Nominal output current In EZMK35-400-2R	2×259A
Nominal output current In EZMK35-800-1R	1×518A
Nominal secondary voltage	4 ÷ 120Hz
Junctions of primary winding	PWM
Unit Type	voltage
Cooling	external water cooling – 25l/min (40°C) in nominal load 100% In
Overload	150% In for 1 min.
Engine Braking	to braking resistors
Marking flameproof electrical equipment	Ⓔ I M2(M1) Ex db [ia Ma] I Mb
Dimensions	2370 x 1315 x 1050 mm
Weight	3500kg
Type transistor in the inverter bridge	IGBT
Type of the control converters	U/f; OPEN LOOP VECTOR
Setting	programming parameters from the keyboard
Protection against network downtime	All operating parameters are stored in memory, they are reproducible and protected against network downtime
More Protection	against voltage surges and power networks, against current overload and short circuit output

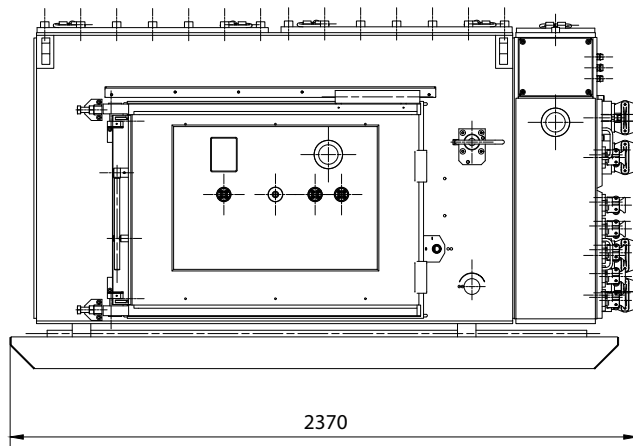
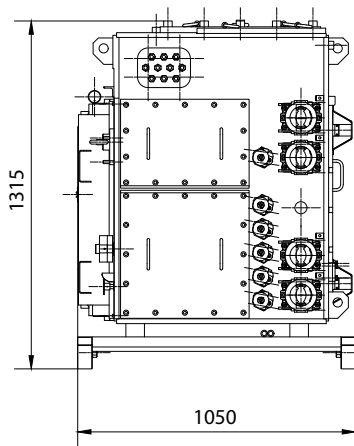

FLAMEPROOF CIRCUIT BREAKER SET

SN54



The flameproof circuit breaker set SN54 is determined for switching and protection of three-phase mining electrical equipment or for switching and protection of a mining supply network.

The flameproof circuit breaker set SN54 is constructed for use in the isolated supply network up to 11 kV 50/60Hz.

The product complies with the technical requirements for devices designed for use in potentially explosive atmospheres of mines according to Directive 2014/34/EU.

The product is designed for use in environment with methane and coal dust explosion hazard category M2, and complies with technical requirements of devices from group I. The product also complies with technical requirements EN 60079-0, EN 60079-1, EN 60079-11 and EN 60529.

Design

The flameproof circuit Breaker Set SN54 is executed in a welded flameproof enclosure. The flameproof enclosure composes of these separate areas: input isolator compartment, main apparatus compartment with a quick-release door, output isolator compartment, main connecting compartments and auxiliary connecting compartment include intrinsically safe circuits. It is possible to make the electrical and mechanical connection of the several flameproof circuit breaker sets SN54 in to the M.V. distribution board.

The flameproof circuit Breaker Set SN54 has got two types of the design

- SN54 – P1 input or coupling circuit breaker
- SN54 – P2 output circuit breaker

Main parts of power electrical circuits are incoming isolator with earth switch, the quick-release door mechanical, electrical interlock, circuit breaker and outgoing isolator with earth switch. The flameproof circuit breaker set SN54 has one auxiliary output 110VAC.

Electric circuits of circuit breaker set ensure the following:

- short circuit and overcurrent protection
- phase failure and phase asymmetry protection
- earth fault protection (used in output circuit breaker version only)
- directional earth fault protection (used in output circuit breaker version only)
- earth fault lock-out protection (used in output circuit breaker version only)
- pilot circuit protection (used in output circuit breaker version only)
- remote intrinsically safe control
- M.V. insulation test is operated on an outgoing power cable only before power circuit breaker switch-on. The injection voltage is a nominal 4000VDC (used in output circuit breaker version only).
- indication of all operation and failure conditions and history saving. All items are displayed on 5.3" display
- remote data transfer

TECHNICAL DATA

Technical parameters	
Type	SN54
Nominal voltage	3 AC 3,3-10kV 50/60Hz
Total nominal current of circuit breaker	630 Amps.
Symmetric nominal off-switching current of circuit breaker	up to 31,5kA at 12kV
Nominal on-switching current (peak) of circuit breaker	up to 80kA at 12kV
Nominal current of busbar	630 Amps.
Maximum number of power inlets	3
Maximum number of switched/protected power outlets	1
Flameproof equipment marking	Ex2(M1) Ex db [ia Ma] I Mb
IAC classification	BFLR 25kA/0,1s
IAC classification	IP54
Total weight	2900kg

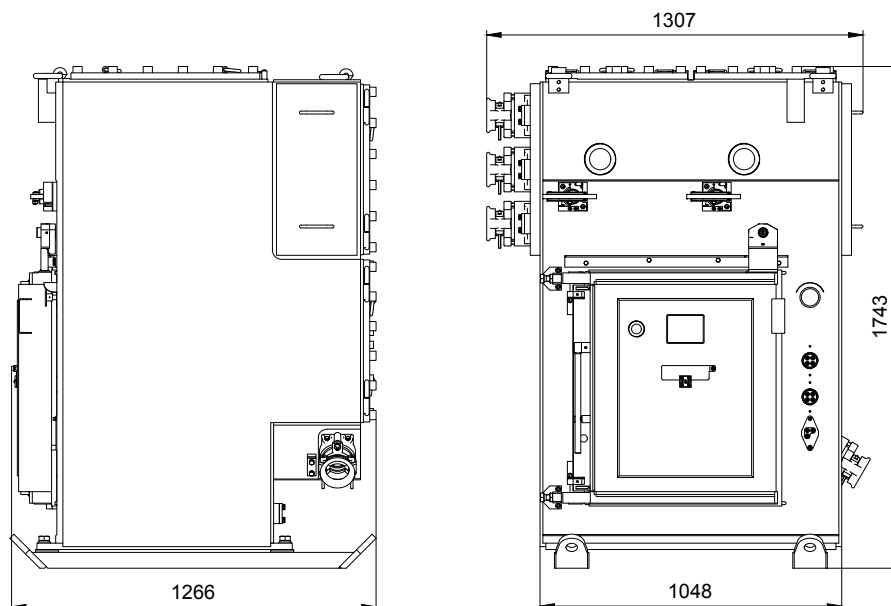

AUTOMATIC CONTROL SYSTEM APD1



The Automatic Control System APD1 is a microprocessor control system designed for central control of conveying in underground and open pit mines. The whole system is classified as being intrinsically safe equipment group I category M2/M1.

This product complies with technical requirements for devices determined for use in potentially explosive atmospheres of mines according to Directive 2014/34/EU.

Main system functions:

- program control, regulation and parameterization of conveyor lines or other machines
- emergency stop (blocking) of machinery
- speech communication along lines
- signalling including transmission of warning signals before re-starting
- monitoring and visualization of the whole mucking process
- data archiving
- easy diagnostics of the whole system and localization of failure from control station on surface or in mine
- access from intranet and internet

Main APD1 system units:

- Central station SC1
- Conveyor station SD1, SD2
- Supply sources OZ12
- Speech amplifier OPZ1, OPZ3
- Locking key OKB1
- Interlock transmitter OPB1
- Deviation sensor SO1
- Temperature sensor ST1
- Telephone converter TP1
- Speed sensor SR1
- Auxiliary control unit OP1
- Cable segments 1-110m

Central station SC1

This surface workstation is the common personal computer. With the help of the supplied software the communication runs along with the conveyor stations. All diagnostic information is accessible online for participants of either the Intranet or the Internet. All information is stored in the archive files, which can be viewed by other users of the Intranet as well as Internet. SC1 enables setting up configuration and branching of conveyor lines, their control, parameterization, diagnostics, localization of failure or defect and others. The communication program is sufficient for simultaneous connection of 18 independent conveyor lines at maximum. The maximum connectable number of conveyors is 465. Along with the communication program the visualization program runs simultaneously. It enables to display the whole process graphically. The visualization program can be started at other stations of the computer network or the Internet.

Setting-up configuration and parameters of conveyor line

Changes can be made easily, without programming skills by operating staff authorized for this action. The program algorithm of the conveyor control is strictly defined at the system production, however, it is possible to adjust it for the required conditions by means of many parameters, like setting-up the sensor type, its negation: setting up the decisive level, program disconnection of sensors, retarding the response at the event of the sensor actuating and retarding the machine's start. These parameters are protected against unauthorized access by secret passwords. All modifications are kept in the archive file and it is possible to check them at any time. Alterations can be made at the Central station as well as the Conveyor station.

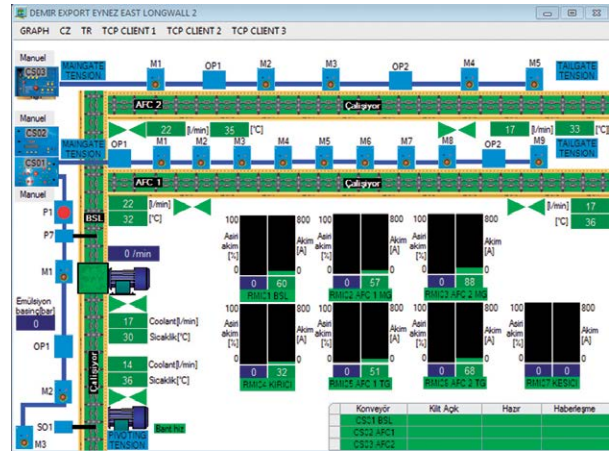

Monitoring conveyor line operation

All information about the conveyor running (state of sensors, state of outputs, information about the place of locking and its cause and others) is accessible on every conveyor station SD. In the diagnostic mode it is possible to display on LCD display all important information concerning the state of sensor inputs, battery source, emergency circuit wires and others. In the same way it is possible to obtain information about failures barring the start. Between the central station and the conveyor station there is a continuous transfer of information. This information is accessible also at the control computer of the Central station. If the computer is connected to the company computer network or the Internet, the data are accessible to all other users of the net communication via protocol TCP/IP. All operational changes are kept in a file, so they are available for any possible further assessment. The period of file storing is selected by the user.

Visualization of the process

The visualization software is supplied along with the system. It facilitates a well-arranged graphic way of displaying the operational states of the drawing line. Staff is informed about the mucking process also through the speech output. Visualization tasks are accessible to the selected working places of the Intranet, or the Internet if required.

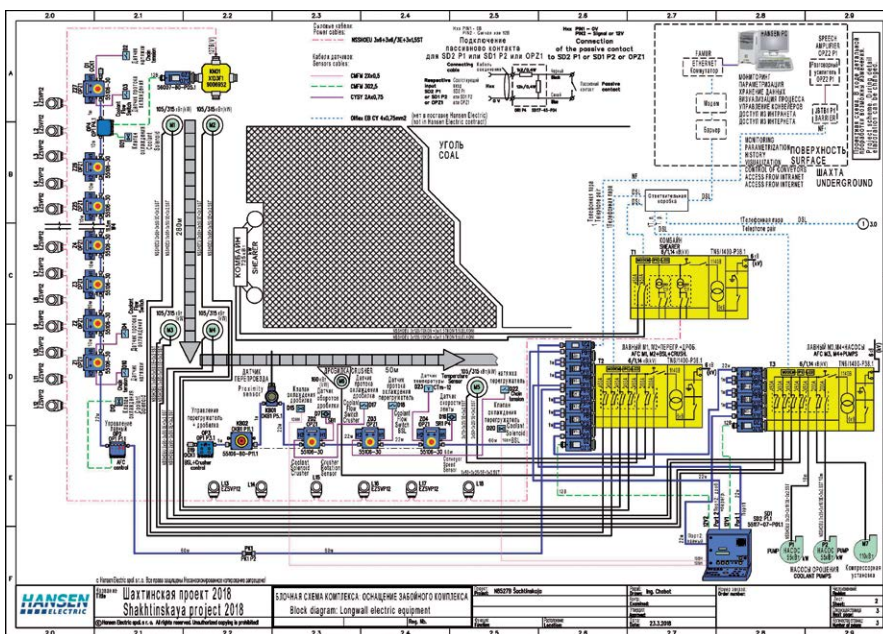

Complete electric solution for mining

APD1 system gives the possibility to deliver end customer complete electric solution for underground mining, including project, commissioning, installation, training from the one supplier of electric equipment.

LIGHT FITTING

EZSVP 13

The mining Light Fitting EZSVP 13 is determined to illuminate the working face of underground mines. The light fitting can be used in all mine premises with danger of explosion of methane.

The product is designed for use in supply mains of 2/PE~90 to 264V, 47 to 63Hz, the source of light is provided by output power LED diodes. The light complies with technical requirements for devices determined for use in potentially explosive atmospheres of mines according to Directive 2014/34/EU.

The Light Fitting EZSVP13 contains from 8 pieces of red LEDs with its own power supply and electrical relay that switches the supply voltage sources for white or red LEDs (maybe lit either white or red LEDs). If we bring to the electronic relay control voltage of the specified size, the white LEDs will go out and the red LEDs will illuminate and the light will be red. When the control voltage is switched off, the luminaire will again be lit by white light.

Technical description

The light is made as a flameproof enclosure welded of steel plates. On the lighting body there is a lid attached by means of hinges. There is a convex plastic inspection window in the lid. The lid is attached to the lighting body by means of seven bolts. There are supply terminals, a fuse, protective terminal, power supply, light unit with LED diodes and two cable bushings. The inner bushings used to provide for the minimized lighting dimensions. There is a protective terminal on the side of the box from the outside. The lighting is attached with four suitable bolts via inlets of a diameter of 13mm which are on the rear board of the lighting. The unit can be mounted in any position.

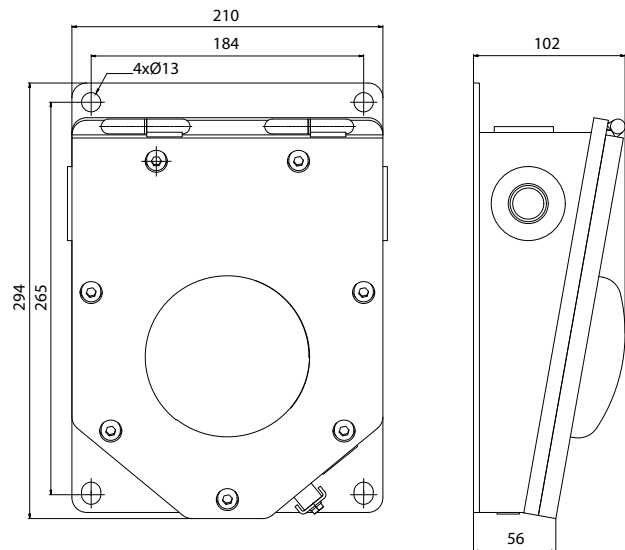

TECHNICAL DATA

Technical parameters	
Nominal supply voltage	90 to 264V / 47 – 63Hz
Nominal input power	max. 35W
Source of white light	14 pcs of LED diode 3W
Flux	min. 3900lm
Source of red light	8 pcs of LED diode 3W
Flux	min. 1300lm
Ambient temperature	-10°C ≤ Ta ≤ +40°C
Marking of explosion-proof	Ex db op is I Mb
Coverage range	IP54
Dimensions	402 x 210 x 79 mm
Lighting weight	13kg

LIGHT FITTING SVN8



The product complies with technical requirements for devices determined for use in potentially explosive atmospheres of mines according to Directive 2014/34/EU. The product also complies with technical requirements EN 60079-0 and EN 60079-1.

The Light Fitting SVN8 is determined to illuminate the working face of underground mines.

The light fitting can be used in all mine premises with danger of explosion of methane.

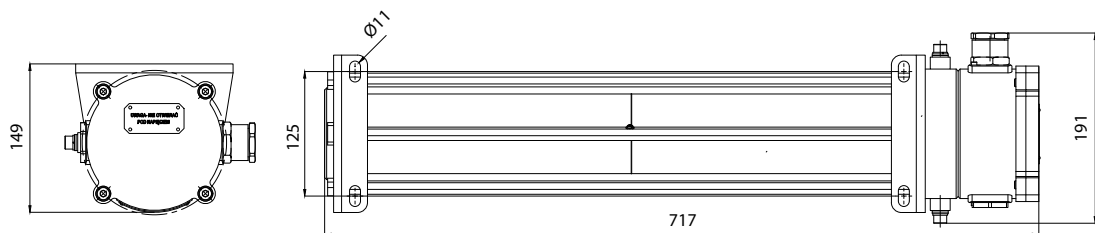

TECHNICAL DATA

Technical parameters	
Voltage supply	200 – 240V AC
Frequency	50 ÷ 60Hz
Light source	24W
Luminous efficacy	≥ 160lm/W
Luminous flux of light source	3800lm
Viewing angle	122°
Correlated colour temperature	4000K, 6000K
Cable glands	2x M36 x 1,5
Connection clamp	10mm ²
Clamp loading	28A
Ambient temperature	-10°C ≤ Ta ≤ +40°C
Marking of devices	Ex d I Mb
Coverage range	IP65
Dimensions	146 x 158 x 721 cm
Weight	8kg

FLAMEPROOF ELECTRIC MOTOR 2HVM



2HVM motors are designed to the power of mining equipment. Motors can be used in underground parts of mines and in surface installations of such mines endangered by an explosion of methane and/or coal dust. Electric motors are included in group I. category M2 according to ATEX directive (2014/34/EU). ATEX labeling IM2 Ex d I Mb.

The Electric Motors are explosion-proof. Type of protection is flameproof enclosure „d“, meeting the requirements and provisions of the standards EN 60079-0, EN 60079-1 and of the series of standards EN 60034. Motors are designed with flange (IM B5) or with flange and feet (IM B35), degree of protection IP 65, insulation class H. For the control of bearings and winding heating is motor equipped with independent thermal sensor circuits (PTC thermistors, NC bimetal sensors or Pt100 sensors). Motors are designed for duty S1.

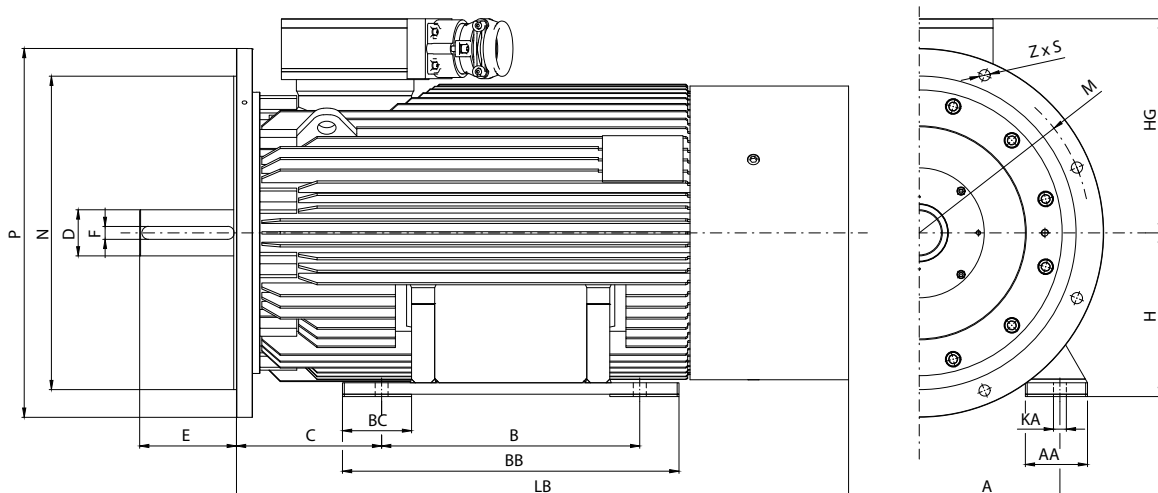

Conditions of operation and application:

Ambient temperature	-20/+40°C	Operating voltage	(0,90÷1,10) U _N
Relative humidity at 35°C	≤ 100%	Slope of the axis of shaft	≤ 30°
Dusty of environment	<1000mg/m ³		

Basic installation dimensions:

Motor type	A	AA	B	BB	BC	C	D	E	F
2HVM 250M-4	406	90	349	445	100	168	60 (65)	140	18
2HVM 280S-4	406	90	368	518	145	187	70 (75)	140	20
2HVM 280M-4	406	90	419	569	145	187	75	140	20
2HVM 355L-4	610	135	560	730	150	315	100	210	28
Motor type	H	HG	KA	LB	M	N	P	S	Z
2HVM 250M-4	250	405	24	887	500	450	550	18.5	8
2HVM 280S-4	280	437	24	863	500	450	550	18.5	8
2HVM 280M-4	280	452	24	955	500	450	550	18.5	8
2HVM 355L-4	355	465	28	1328	740	680	800	24	8

TECHNICAL DATA

Motor type	Power [kW]	Torque [Nm]	Speed [min ⁻¹]	Voltage [V]	Current [A]	Frequency [Hz]	PF cos φ [-]	Efficiency η [%]	Mass IM B3 IM B35 [kg]
2HVM 250M-4	55	358	1473	400	100.0	50	0.88	93.6	655 687
				500	80.0				
				660	60.6				
				690	58.0				
				1000	40.0				
				1100	36.4				
	1140	35.1							
	66	358	1776	440	90.0	108.8	60	0.86	
0.85					92.8				
2HVM 280S-4	75	486	1481	400	132.5	50	0.88	93.2	765 780
				500	106.0				
				660	80.3				
				690	76.8				
				1000	53.0				
				1100	48.2				
				1140	46.5				
2HVM 280M-4	100	645	1481	500/1000	138.0/69.0	50	0.90	92.9	890 935
				660/1140	104.5/60.5				
				690	100.0				
				1100	62.7				
2HVM 355L-4	250	1608	1487	1000	170.0	50	0.90	94.3	1860 1910
				1100	154.5				
				1140	149.1				

VACUUM CONTACTORS

HR-VS



The Vacuum Contactor HR-VS is an electromechanically operated device determined for frequent switching of exclusively alternating current circuits with voltage up to 1200V according to EN 60947-1 and EN 60947-4-1 with currents of up to 630A in the range of closing and breaking currents corresponding to AC4 category. This contractor is used particularly for switching of squirrel cage and slip-ring motors. It is suitable for switching of resistance and mixed loads.

Technical merits

- high-reliability
- long lifetime
- minimum maintenance demanded during its whole lifetime
- high frequency of repeated switches
- small size and low weight
- high climatic resistance

Material and design

All structural parts of the contactor housing are moulded of polyester resin filled with glass fiber. The relay magnet coil former is made of Silamid. International protection IP00.

The Vacuum Contactor is designed for operation in a conventional indoor environment and the following values:

- the ambient temperature for 550A – from -20°C to +60°C
- relative humidity at 20°C – max. 80%
- altitude – max. 1000m
- working position – vertical
- deflection in any direction – max. 10°

TECHNICAL DATA

Technical parameters HR-VS4/630 HR-VS4 HR-VS3 HR-VS200 HR-VS80						
Nominal operational and insulation voltage		500 ÷ 1200V				
Nominal operational and thermal current		630A 450A 315A 200A 80A				
Utilisation category		AC1 ÷ AC4				
Frequency		50/60Hz				
Number of poles		3				
Nominal switching capacities making current		7560A	4800A	3800A	2400A	960A
Nominal switching capacities breaking current		6300A	4000A	3150A	2000A	800A
Nominal short-time current 1.0s		6kA	4.8kA	5kA	3.2kA	1.34kA
Nominal dynamic current		20kA	18kA	12.5kA	16kA	2.36kA
Max. breaking capacity (cosφ=0,35)		7kA	6kA	5kA	4kA	2.5kA
Class of interrupted operations 1200		1200 cycles/hour				
Mechanical lifetime		1x10 ⁶ cycles				
Electrical lifetime	for AC6	3x10 ⁵ cycles				
	for AC6	1x10 ⁵ cycles				
Protection		protected by fuse with aM characteristic				
Nominal control voltage		120/230V, 50Hz / +15% ... -25%				
Continuous consumption		6VA	5.3VA	5.3VA	3.2VA	9VA
Closing time		≤ 65ms ≤ 45ms		≤ 30ms		
Breaking time		≤ 35ms ≤ 30ms		≤ 40ms		
Auxiliary contacts		3xNO, 2xNC / 2xNO, 3xNC				
Weight		9kg 4,7kg 1,8kg				
Dimensions (A x B x C)		186 x 198 x 186 mm 134 x 130 x 158 102 x 109.5 x 134				

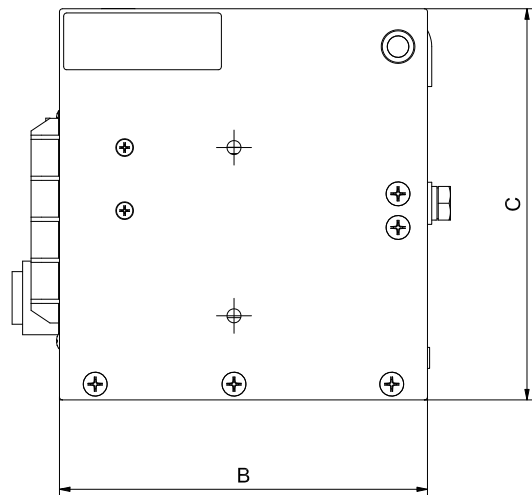
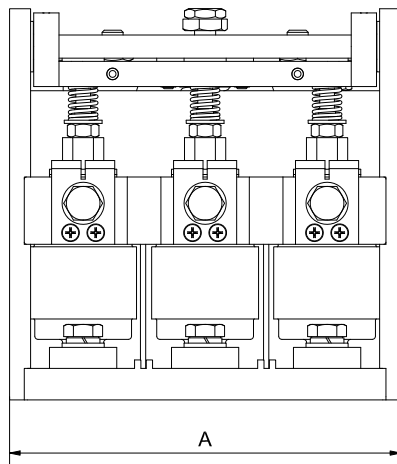

Dimension drawing (example)



HANSEN
ELECTRIC

HANSEN
ELECTRIC
POLSKA

HANSEN
SIB

HANSEN
УКРАИНА



Czech Republic
Hansen Electric, spol. s r.o.

Tešinská 2977/79C
746 01 Opava
+420 553 816 958
info@hansen-electric.cz
www.hansen-electric.cz



Poland
Hansen Electric Polska Sp. z o.o.

ul. Dojazdowa 23
43-100 Tychy
+48 32 726 76 31
info@hansen-electric.pl
www.hansen-electric.pl



Russian Federation
ООО „Сиб-Ханзен“

ул. Ульяновская 5,
652507 г.Ленинск-Кузнецкий
Кемеровская область
+7 38456 33987
sib-hansen@rambler.ru



Ukraine
ООО „Ханзен Електрик Україна“

01011, м. Київ,
вулиця Рибальська,
будинок 13, офіс 4
+380 50 422 4305
vikt.poteraylo@gmail.com

HANSEN
ALAGRUP

HANSEN
JANEL

HANSEN
ELECTRIC
IRANIAN



Turkey
Hansen Alagrup Ltd. Şti.

Gersan Sanayi Sitesi
Tahsin Kahraman Cad No:65
Batikent/Ankara/Turkey
+90 312 473 57 51
elektrik@alagrup.com



China
Hansen Janel Trade Co., Ltd

Zhen Xing South Road,
Cheng Hang
215600 Zhang Jia Gang City
Jiangsu Province
+86 13 910337763
hansenjanel@163.com



Iran
Hansen Electric, Ir. PJS Co

Isfahan, 8186798337
Atashgah St. 49, Khorsandi Alley
+98 313 773 7058
hadis.ghasemi@hansen-electric.ir
www.hansen-electric.ir



Download 3D application HANSEN ELECTRIC

www.hansen-electric.cz